

# HEATSTRIP<sup>®</sup>

R A D I A N T   O U T D O O R   H E A T E R S



## Product Manual



## HEATSTRIP<sup>®</sup> Classic (THH-A)

*The heater that is a design feature!*





## Product Overview

Rev E JUL13

There are three (3) different series of products within the Heatstrip® product category. Each has a different temperature output, making them ideal for different applications. Below is a list of some common applications, to assist with the selection of the most effective and efficient series. This will assist in selecting the ideal range, prior to proceeding further.

This is a general guide only, please refer to the Product Manual for each product, for more information.

**HEATSTRIP® Classic** (THH-A models) is a premium high temperature heater and is primarily used for outdoor rooms where there is 1,2 3, or 4 enclosed sides, with an ideal mounting height of 2.1 m to 2.7m.

**HEATSTRIP® Max** (THX models) is an ultra high temperature heater used for uncovered or open indoor or outdoor areas with a mounting height of 2.4 m to 3.5m.

**HEATSTRIP® Indoor** (THS-A models) is a medium intensity heater used for protected indoor applications.

APPLICATION	THS	THH	THX
Indoor insulated areas, classrooms, offices, bathrooms, wet areas, drying rooms	√	√	X
Outdoor under cover, café, veranda, patio, balcony ceiling height 3m or less	X	√	√
Outdoor under cover, café, veranda, patio, balcony ceiling height 3m or more	X	X	√
Highly exposed outdoor area	X	X	√
Indoor open area, warehouse, factory, production areas, sports facilities	√	√	√
Indoor spot heating, above tables, assembly areas	X	√	√



Heatstrip Indoor (THS-A)



Heatstrip Classic (THH-A)

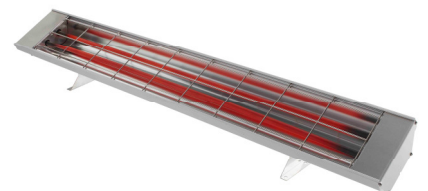

Heatstrip Max (THX)



## Why choose Heatstrip® electric radiant heaters for your outdoor or hard-to-heat indoor area?

As there is typically constant air movement in an outdoor or open indoor area, many conventional patio heaters rely on convection heating which works by heating the surrounding air. This can be quite impractical for these areas, as this heated air can easily blow away with natural air movement. Radiant style heaters transfer heat directly to objects through infra-red waves.

Whilst convection heaters heat the air in between objects, radiant heaters heat the surface of the objects themselves. HEATSTRIP® electric radiant heaters are more effective within an outdoor or uninsulated indoor area because they provide targeted warmth directly to the people and objects in their path.

### Discrete, stylish heating for undercover outdoor and indoor open areas

Using the radiant heating principle, HEATSTRIP® can provide effective and energy efficient comfort heating for undercover outdoor and indoor open areas. HEATSTRIP® has successfully enabled many entertainment venues such as restaurants, pubs and clubs to utilise their outdoor dining areas day and night, through all seasons. Within your workplace or business, HEATSTRIP® can provide comfort heating for designated outdoor smoking and leisure areas, as well as for workstation spot heating in factories, warehouses and showrooms. Within your home, HEATSTRIP® can provide comfort heating for undercover alfresco dining and BBQ area, patios, verandas, courtyards and balconies.

### Subtle, minimalist design

The stylish, slimline black face of the HEATSTRIP® does not emit light or glow when in use, blending elegantly into your décor. Ceiling, wall and umbrella mounting options ensure that your valuable floor and table space is not wasted.

### Efficient, cost effective electric heating

The innovative design of the HEATSTRIP® enables comfortable and even heat dispersion from the heater surface with minimal operating costs.

### Design flexibility

Four HEATSTRIP® models are available, ensuring the heating requirements of any undercover outdoor or open indoor area is possible. Brackets for direct ceiling or wall/ceiling angled mounting are supplied as standard.

Optional HEATSTRIP® accessories include beam or fixed umbrella mount brackets, extension mount brackets, chain suspension brackets, twin mount brackets and flush mounting enclosures.



### Minimal maintenance

The HEATSTRIP® incorporates no internal moving parts ensuring quiet and virtually maintenance free operation.

### Australian Product

Designed, engineered and assembled in Australia the HEATSTRIP® Classic is fully backed by a 24 month residential warranty, and 12 month commercial warranty.

### Stylish design— *The Heater that is a Design Feature!*

The attractive HEATSTRIP® comes with a standard black face and anodised alloy rear casing.

### Easy to use

The standard HEATSTRIP® Classic is controlled by a simple on/off operation, either when plugged directly into a power point, or hard-wired via a wall mounted on/off switch. The unit takes approximately 15 minutes to heat up to maximum temperature and approximately 30 minutes to cool down, depending upon the ambient temperature. Please don't forget to turn it off.

We recommend installing your HEATSTRIP® with a timer controller to ensure the unit is turned off after a preset time. Thermofilm recommends Model TT-MTM controller, which includes a timer function and temperature control.



## Specifications - Australia

MODEL	POWER (WATTS)	CURRENT (AMPS)	DIMENSIONS (mm)	WEIGHT (Kg)	LEAD LENGTH (mm)	PLUG
THH1500A	1500	6.3	924 x 165 x 48	5	1000	YES
THH1800A	1800	7.5	1104 x 165 x 48	6	1000	YES
THH2400A	2400	10	1364 x 165 x 48	7	1000	YES
THH3200A	3200	13.3	1774 x 165 x 48	9	500	NO

MODEL							
HEATER TYPE	High intensity electric radiant overhead heater with high surface area profiled alloy						
OUTPUT	Refer to model code chart above						
POWER	230-240 Volts Nominal at 50—60 Hertz, Single Phase						
CONNECTION	3 Core Cable 2.5mm <sup>2</sup>						
APPROVALS	AUSTRALIA/NZ						
MOUNTING HEIGHT	<table border="0"> <tr> <td>MINIMUM</td> <td>2.1 m</td> </tr> <tr> <td>RECOMMENDED</td> <td>2.3 m to 2.7 m</td> </tr> <tr> <td>MAXIMUM</td> <td>3.0 m in a fully enclosed outdoor area (For higher ceiling heights, units can be lowered using optional bracket kits or refer to the Heatstrip Max range)</td> </tr> </table>	MINIMUM	2.1 m	RECOMMENDED	2.3 m to 2.7 m	MAXIMUM	3.0 m in a fully enclosed outdoor area (For higher ceiling heights, units can be lowered using optional bracket kits or refer to the Heatstrip Max range)
MINIMUM	2.1 m						
RECOMMENDED	2.3 m to 2.7 m						
MAXIMUM	3.0 m in a fully enclosed outdoor area (For higher ceiling heights, units can be lowered using optional bracket kits or refer to the Heatstrip Max range)						
MOUNTING OPTIONS	Suitable for ceiling, wall, beam, fixed umbrella and recess mounting. Also available for extension mount using rigid fixing poles and chain mount bracket.						
PROTECTION RATING	IP55 Protection from water ingress from all directions						
COUNTRY OF MANUFACTURE	Australia						

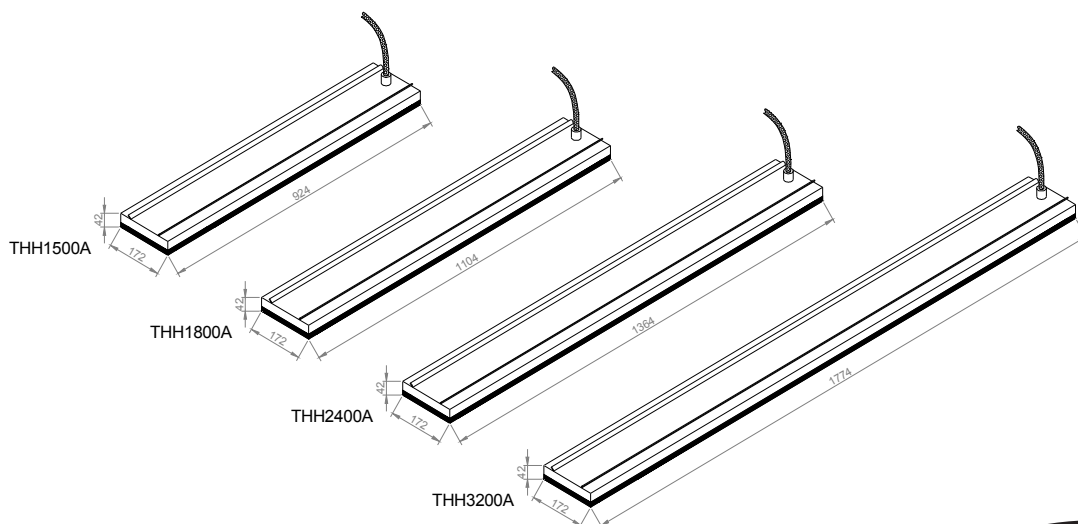



## Specifications - International

HEATSTRIP® is supplied to many international markets, and therefore is available in a range of voltages and lead configurations, in order to meet local market approvals. HEATSTRIP® is fully compliant to the following international standards.

Europe CE, ROHS, IEC 60335-2-30:2002

USA/Canada UL/CSA E321442

Japan PSE

MODEL	REGION	VOLTAGE (Volts)	POWER (WATTS)	CURRENT (AMPS)	DIMENSIONS (mm)	WEIGHT (Kg)	LEAD LENGTH (mm)	PLUG
THH1500AEU	EUROPE	230	1500	6.3	924 x 165 x 48	5	1000	YES 230V
THH1800AEU	EUROPE	230	1800	7.5	1104x 165 x 48	6	1000	YES 230V
THH2400AEU	EUROPE	230	2400	10	1364 x 165 x 48	7	1000	YES 230V
THH3200AEU	EUROPE	230	3200	13.3	1774 x 165 x 48	8	500	NO
THH1500AUK	UNITED KINGDOM	240	1500	6.3	924 x 165 x 48	5	1000	YES 240V
THH1800AUK	UNITED KINGDOM	240	1800	7.5	1104x 165 x 48	6	1000	YES 240V
THH2400AUK	UNITED KINGDOM	240	2400	10	1364 x 165 x 48	7	1000	YES 240V
THH3200AUK	UNITED KINGDOM	240	3200	13.3	1774 x 165 x 48	8	500	NO
THHA1500UL	NORTH AMERICA	115	1500	6.3	924 x 165 x 115	5	NONE	NO
THHA2400UL	NORTH AMERICA	240	2400	10	924 x 165 x 115	7	NONE	NO
THHA3200UL	NORTH AMERICA	240	3200	13.3	924 x 165 x 115	9	NONE	NO
THHA2400UM	NORTH AMERICA	208	2400	10	924 x 165 x 115	7	NONE	NO
THHA3200UM	NORTH AMERICA	208	3200	13.3	924 x 165 x 115	9	NONE	NO
THH1300AJP	JAPAN	100	1300	6.3	924 x 165 x 48	5	1000	YES 100V
THH1400AJP	JAPAN	200	1400	7.5	924 x 165 x 48	5	1000	YES 200V
THH1600AJP	JAPAN	200	1600	10	1104x 165 x 48	6	1000	YES 200V



## Operating cost comparison

In many instances, patio heaters powered by gas bottles are used as an outdoor heating source. The below table shows the operational cost comparison between HEATSTRIP® and a bottled gas outdoor heater. The hourly running costs are considerably less and with HEATSTRIP® you never have to worry about running out of gas; no refilling; no unattractive gas bottle to waste space and HEATSTRIP® actually improves the value of your property.

RUNNING COST	OUTDOOR GAS HEATER	HEATSTRIP® ELECTRIC RADIANT HEATER			
		THH1500A	THH1800A	THH2400A	THH3200A
PER HOUR*	\$2.78/hr	\$0.30/hr	\$0.36/hr	\$0.48/hr	\$0.64/hr
PER YEAR**	\$500.00	\$54.00	\$64.80	\$86.40	\$115.20

### Notes:

- Calculations of hourly running cost for outdoor gas heater is based on \$25.00 average to fill a 9kg gas bottle and average running time of 9 hours.  $\$25.00 / 9 \text{ hours} = \$2.78 \text{ per hour}$
- Electricity rate of 20.0 cents/kWh
- All calculations are excluding GST.
  - 1.5kW x 0.20 cents = \$0.30 or 30 cents per hour
  - 1.8kW x 0.20 cents = \$0.36 or 36 cents per hour
  - 2.4kW x 0.20 cents = \$0.48 or 48 cents per hour
  - 3.2kW x 0.20 cents = \$0.64 or 64 cents per hour

Calculations of yearly running cost are based on 180 hours usage

- 180 hours x \$2.78 = \$500.40 yearly running cost for outdoor gas heater
- 180 hours x \$0.30 = \$54.00 yearly running cost for 1500W HEATSTRIP®
- 180 hours x \$0.36 = \$64.80 yearly running cost for 1800W HEATSTRIP®
- 180 hours x \$0.48 = \$86.40 yearly running cost for 2400W HEATSTRIP®
- 180 hours x \$0.64 cents = \$115.20 yearly running cost for 3200W HEATSTRIP®





## Spot heating principle

In most outdoor or difficult-to-heat indoor applications, there are 2 options when looking at the size and quantity of the heater required.

Option 1 is to comfort heat the entire area based on the total dimensions of the space, regardless of whether the entire area is being fully occupied.

Option 2 is to spot heat the high use areas, such as over outdoor tables, BBQ's, lounges, assembly lines or indoor workstations.

Often it is more practical and efficient to spot heat these areas. Spot heating will help to reduce the initial capital cost, as well as the running costs. Spot heating will allow the area to be "zoned", meaning heating only the areas that are being used, such as tables in a restaurant or outdoor alfresco area.

The top table shows a comparison between spot heating over a table, or heating an entire area. The bottom table shows the flexibility of using HEATSTRIP® to provide a comfortable environment, even when the layout of the area is very unusual.

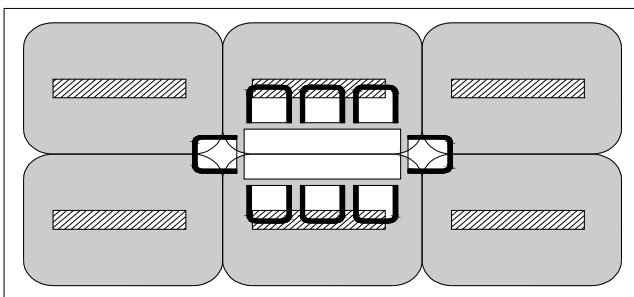

6 x THH2400

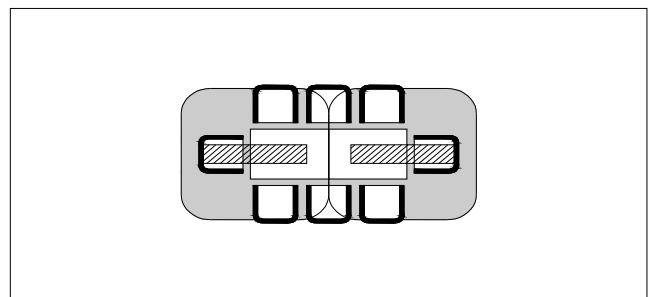

2 x THH2400

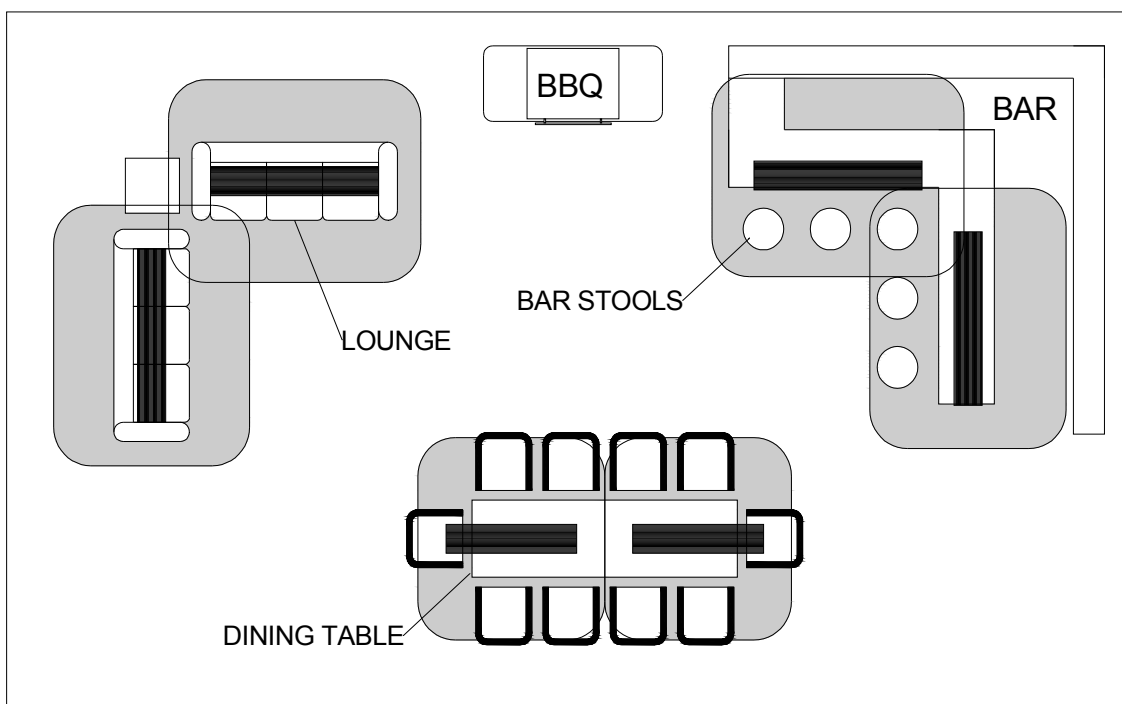



## Radiant footprint

HEATSTRIP® electric heaters produce radiant heat which heats objects rather than the air. Therefore, it is imperative that objects to be heated (ie. people), are within the direct radiant footprint of the heater.

The diagram to the left shows the radiant footprint of HEATSTRIP® Classic, and is an approximate guide based on a fully enclosed, outdoor environment.

This diagram shows that the maximum heat output is found directly under the heater, and the temperature decreases as you move away from the heater.

It highlights the importance of maintaining recommended mounting heights, and if possible, positioning the heater directly above the area to be heated.

Also, the temperature (ie. surface temperature) is the same for all 4 models, regardless of the wattage. However, as the size increases and the length of the unit increases, the radiant footprint will be larger.

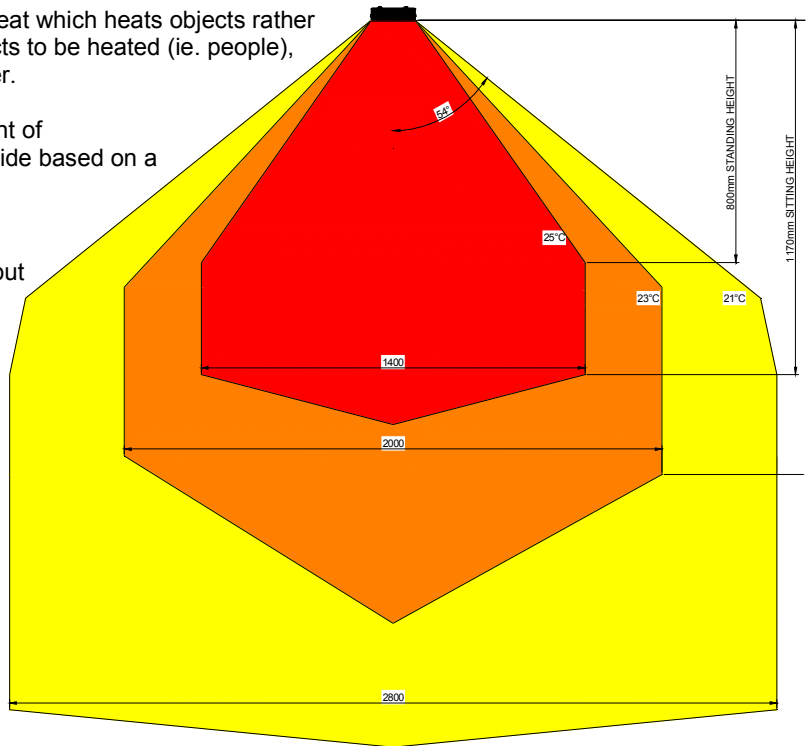

The below diagrams show the approximate heating area for each model, based on both an indoor and outdoor enclosed environment, with direct overhead mounting.

Radiant footprint is reduced in angled, wall mounted applications.

### HEATED AREA

INDOOR SPOT HEATING

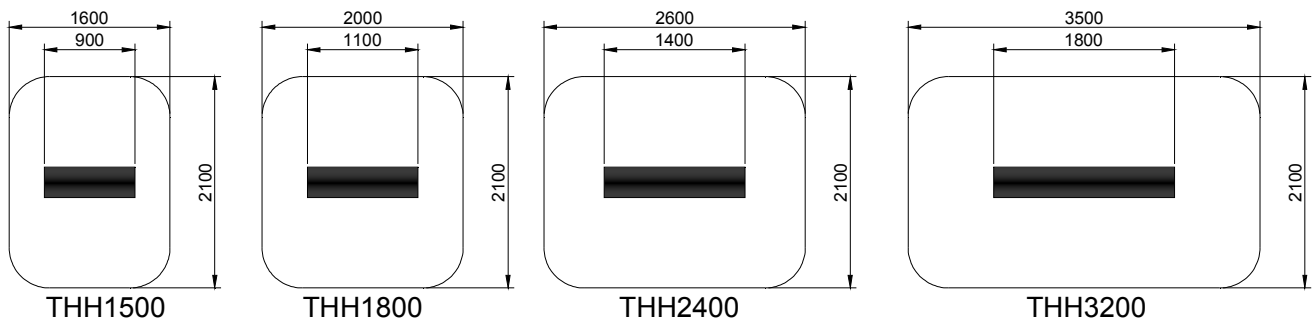

### HEATED AREA

OUTDOOR ENCLOSED AREA

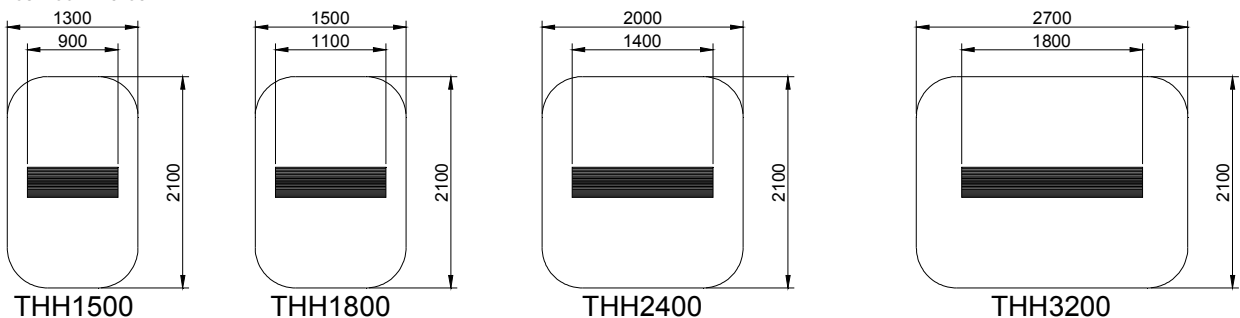



## Selection guide

General recommendations for **HEATSTRIP® Classic**:

- Ideal mounting height: 2.1m to 2.7m. Maximum is 3m in a fully protected/enclosed outdoor environment.
- Ideal mounting location: ceiling mounted, directly above area to be heated (eg. above a table)
- Based on the radiant footprint of the previous page, for a protected outdoor area, a minimum of 500W/m<sup>2</sup> is required. For indoor spot heating, a minimum heating capacity of 400W/m<sup>2</sup> is recommended.

The below table outlines the coverage of each **HEATSTRIP® Classic** model (in m<sup>2</sup>), based on 3 different scenarios, with direct overhead mounting. For example, for an outdoor area that is protected from prevailing winds by walls, café blinds etc, Model THH 1500A will cover 3m<sup>2</sup> and Model THH2400A will cover 4.8m<sup>2</sup>.

For angled wall mounting applications, the coverage can be reduced by up to 40%. The maximum heat projection from the wall is 2m.

MODEL	INDOOR PROTECTED (m <sup>2</sup> )	OUTDOOR ENCLOSED (m <sup>2</sup> )	OUTDOOR EXPOSED (m <sup>2</sup> )
THH 1500A	3.75	3	2.5
THH 1800A	4.5	3.6	3
THH 2400A	6	4.8	4
THH 3200A	8	6.4	5.3





## Table layout

For the majority of outdoor applications, the most effective method is to spot heat a table or similar area. The below diagrams provides an easy selection guide for the approximate model and quantity of heaters required to heat common residential table settings.

Selections are based on HEATSTRIP® Classic being mounted at 2.4m from the floor and an undercover fully enclosed outdoor area.

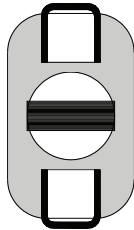

THH1500

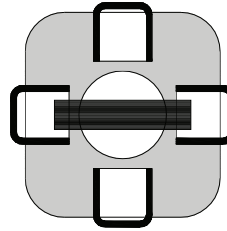

THH2400

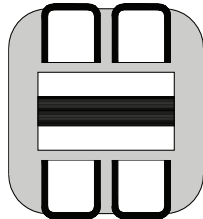

THH2400

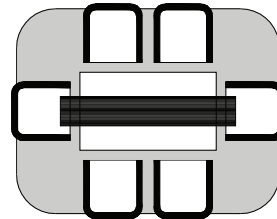

THH3200

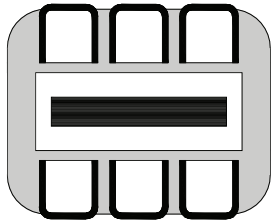

THH3200

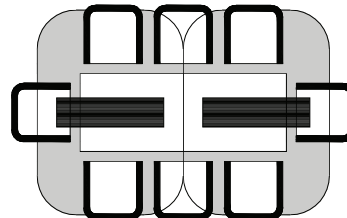

2 x THH1800

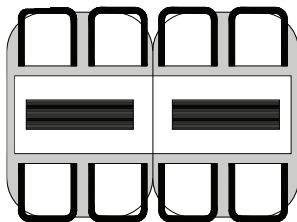

2 x THH1800

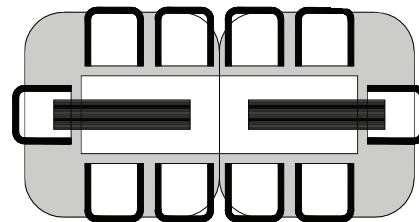

2 x THH2400

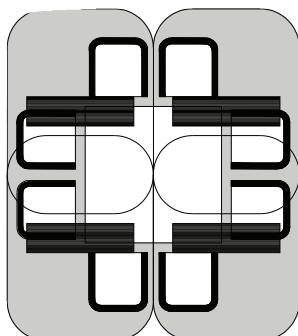

4 x THH1800

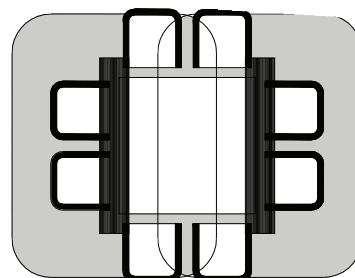

2 x THH3200



## Installation Requirements

The ideal mounting position for the HEATSTRIP® Classic is on the ceiling, directly above the area to be heated. If this is not possible, HEATSTRIP® can be mounted on a wall and angled downwards. In this situation, ensure the mounting height is in the range of 2.1m to 2.7m and the table is within 2.5m of the wall.

For mounting heights more than 3m, we recommend the use of the optional accessories to reduce the height of the heater to 2.3m—2.7 m. This will increase the effectiveness of your HEATSTRIP® Refer to the Mounting Accessory section for more information.

Electrical connections/GPO's should not be located at the back of the heater. They should be located outside the physical footprint of the units to minimize heat build-up behind the units.

If the heater is to be mounted on an incline (eg. Vaulted ceiling), ensure the electrical connection is located at the lowest point of the heater.

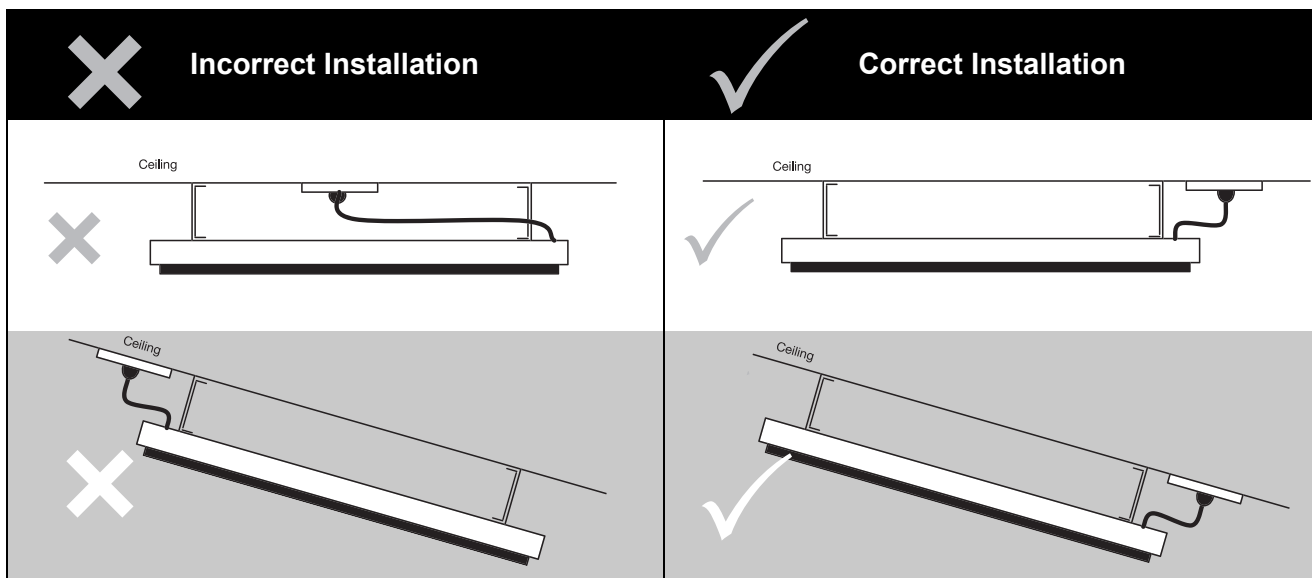

CEILING

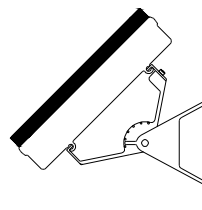

The heating surface must never be directed toward the ceiling



## Installation location —the below diagrams confirm the minimum recommended clearances.

LIGHT, FAN OR SPRINKLER MUST NOT BE BELOW THE HEATER

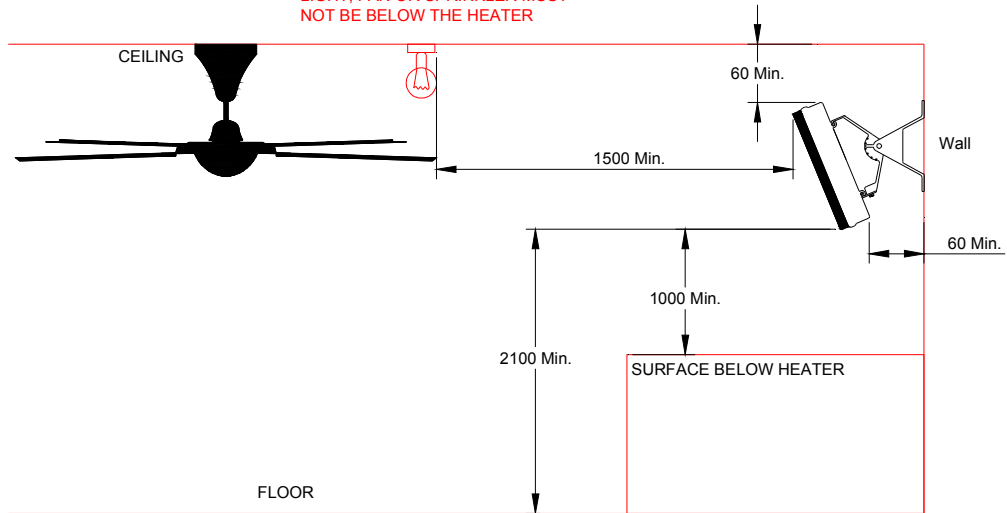

### Angled Wall Installation

LIGHT, FAN OR SPRINKLER MUST NOT BE BELOW THE HEATER

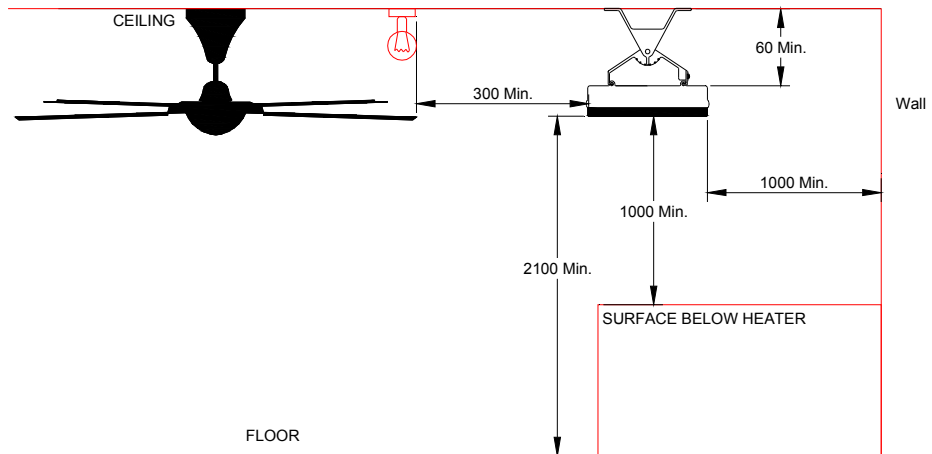

### Ceiling Installation

LIGHT, FAN OR SPRINKLER MUST NOT BE BELOW THE HEATER

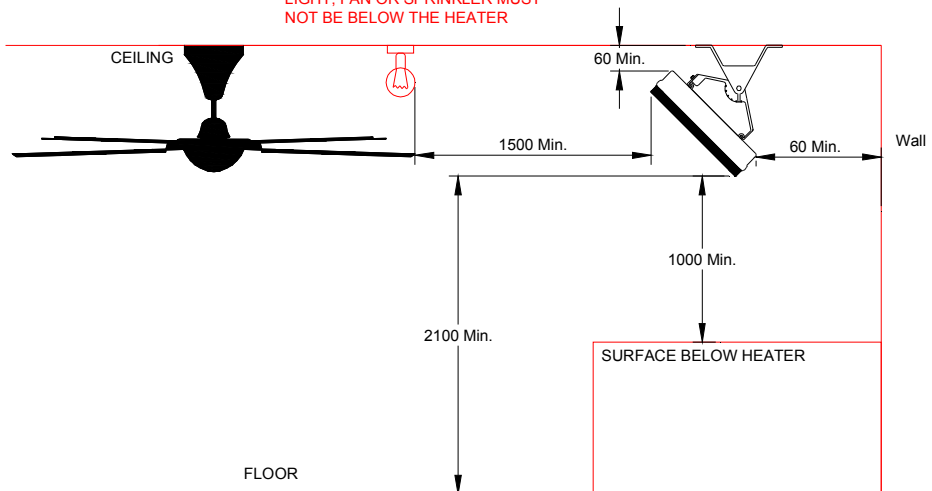

### Angled Ceiling Installation



## Mounting options

The installation of HEATSTRIP® Classic is simple and easy with the standard mounting brackets supplied. For other more challenging locations there are range of mounting options available - refer to below diagrams.

The HEATSTRIP® Classic can be mounted directly to the ceiling, angled downwards on a wall, fitted flush with the ceiling; suspended on chains or poles; attached to beams or poles; mounted end-to-end, or 2 units together. Refer to the following pages for more detailed information on each mounting option.

### CEILING

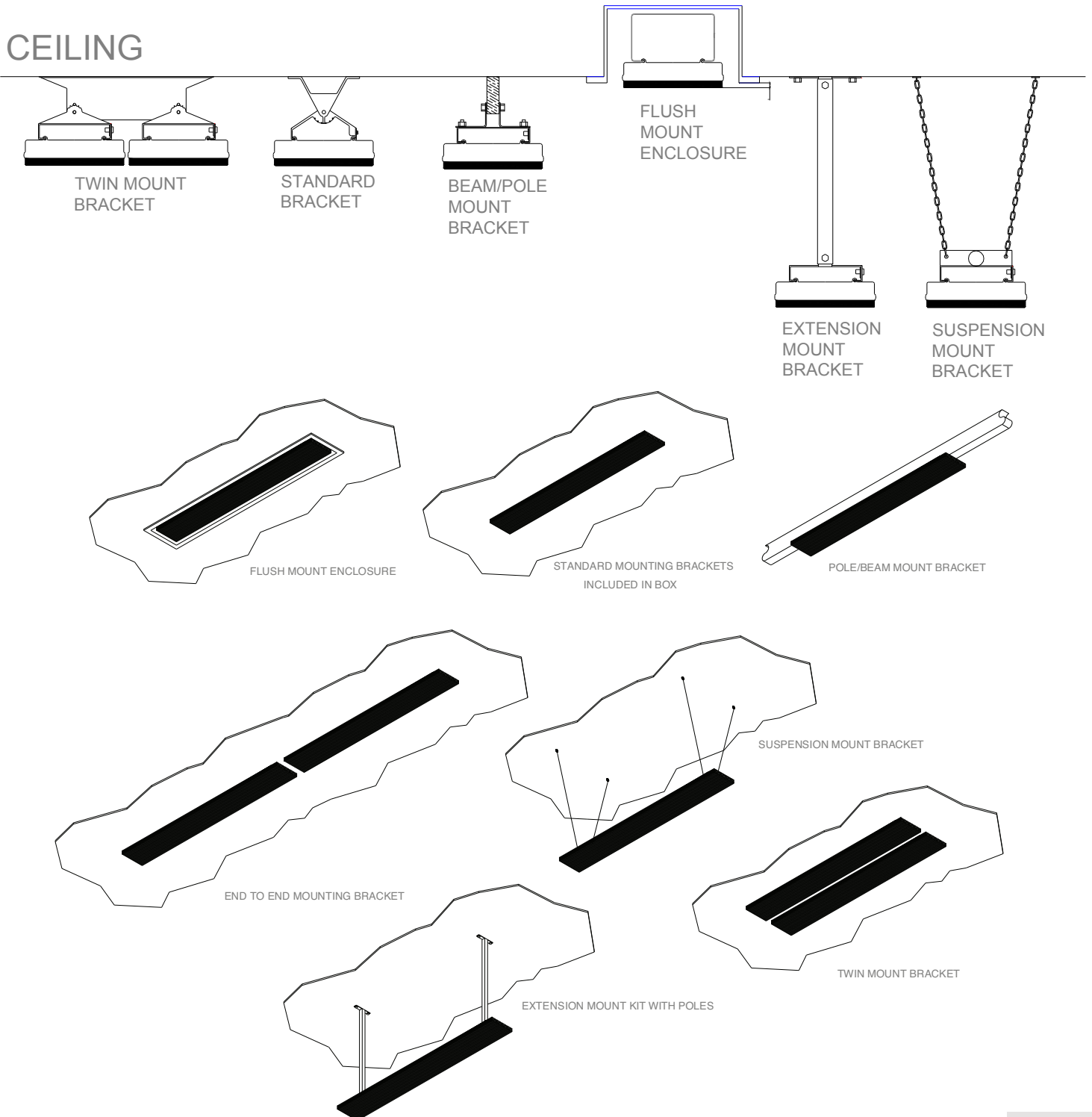



## Standard mounting brackets

The HEATSTRIP® Classic comes with a pair of standard mounting brackets. These adjustable brackets allow direct ceiling or wall mount, and come with preset angle options of parallel, 22.5° and 45°.

CEILING

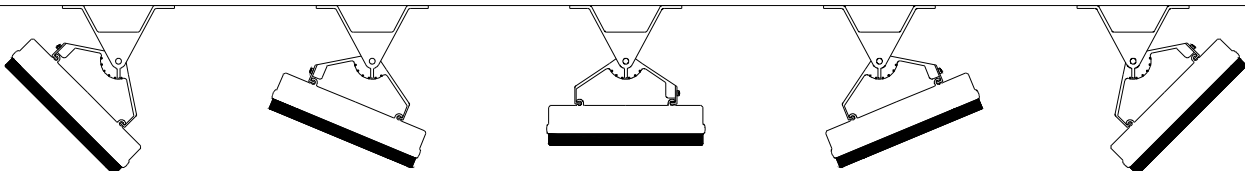

45°

22.5°

PARALLEL

22.5°

45°

MODEL	"B" MINIMUM DISTANCE (mm)
THH1500A	550
THH1800A	710
THH2400A	1000
THH3200A	1470

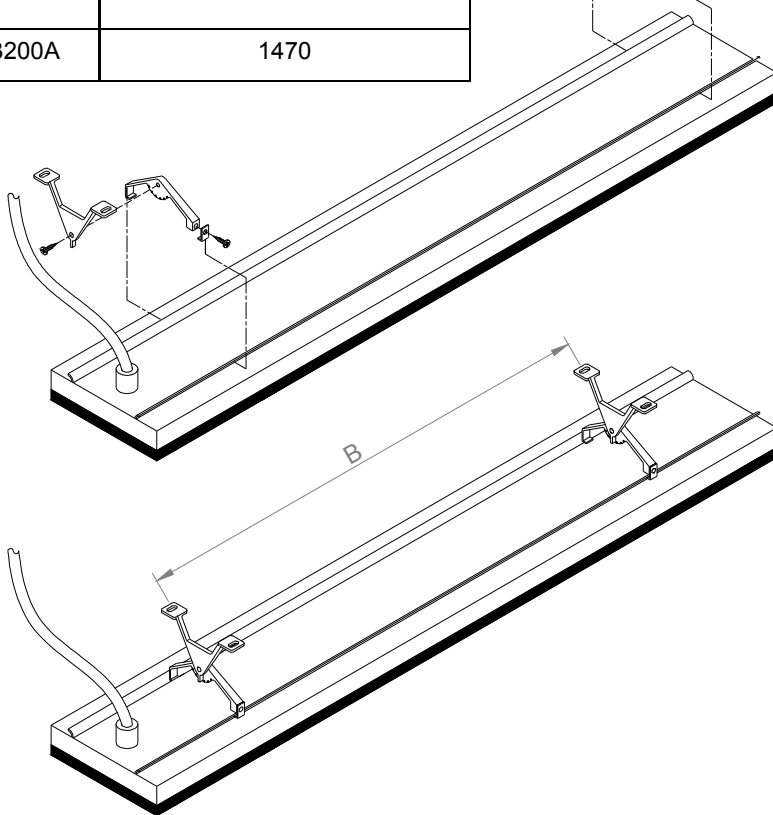
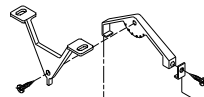

22.5°

45°

WALL

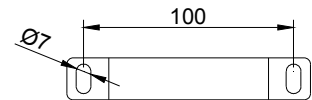

PART No	PACKAGED DIMENSIONS (mm)	WEIGHT (kg)	MATERIALS
ZBRAK-103	125 x 150 x 40	0.2	ALLOY

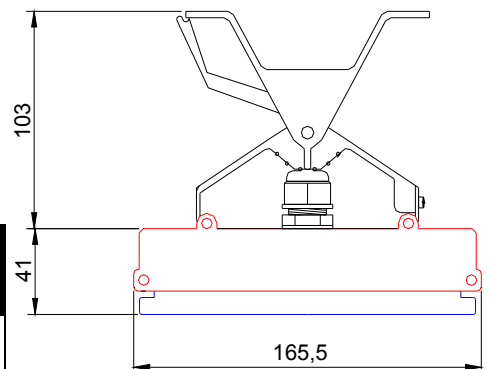



## Flush mount enclosure

The Flush Mount Enclosure is an ideal way to neatly install the HEATSTRIP® into a ceiling. They are available for all HEATSTRIP® Classic models, and are supplied as a one-piece unit for mounting of heaters. Flush mounting can be used with plaster or wood lined ceiling materials.

An ideal mounting height is 2.5m-2.7m, with a maximum ceiling height of 3.0m in an outdoor enclosed environment. Maximum mounting heights should be strictly followed, otherwise the performance of the units may be reduced.

The fascia of the enclosure is manufactured from 316 Stainless Steel and the rear casing is black zinc coated steel. Please refer to the Installation Manual for more detailed installation information.

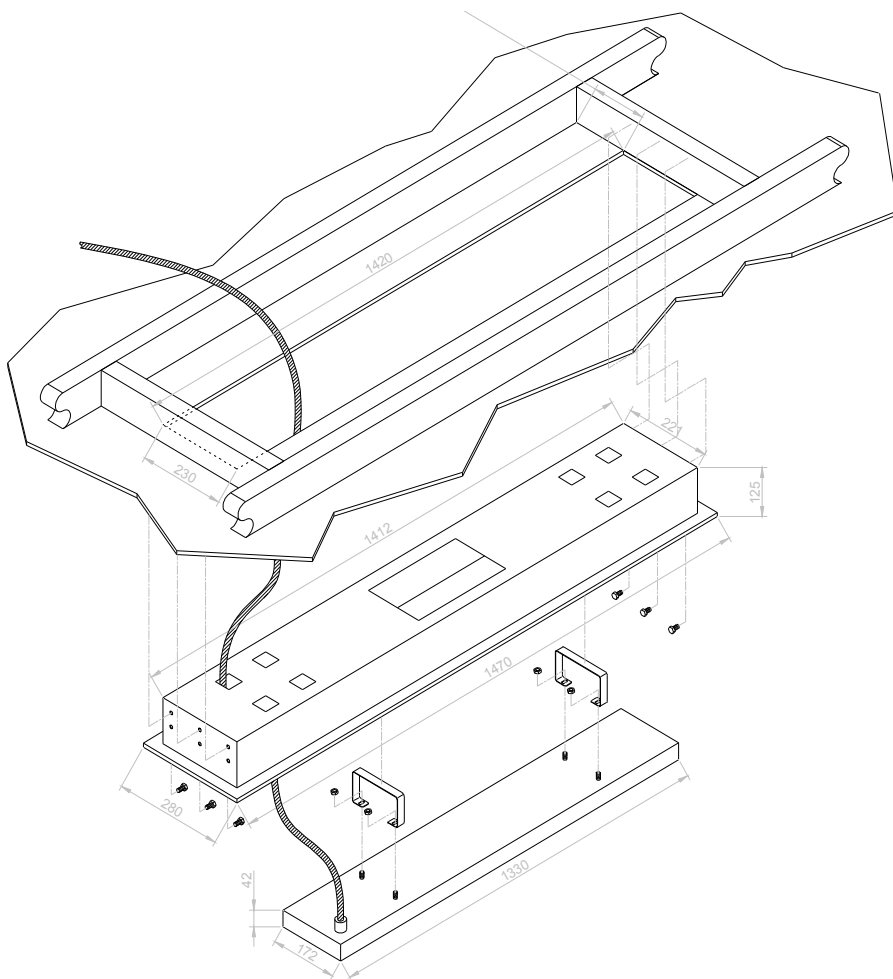

SUITABLE FOR MODELS	PART No	HOLE CUTOUT DIMENSIONS (mm)	OVERALL DIMENSIONS (mm)	WEIGHT (kg)
THH 1500A	THHAC-009	980 x 230	1030 x 280 x 125	5.5
THH 1800A	THHAC-010	1160 x 230	1210 x 280 x 125	6
THH 2400A	THHAC-011	1420 x 230	1470 x 280 x 125	8
THH 3200A	THHAC-012	1830 x 230	1880 x 280 x 125	9



## Pole / beam mounting kit

The optional Pole/Beam mounting bracket kit can be used to mount HEATSTRIP® Classic onto wooden beams, rafters, poles, umbrellas struts etc.

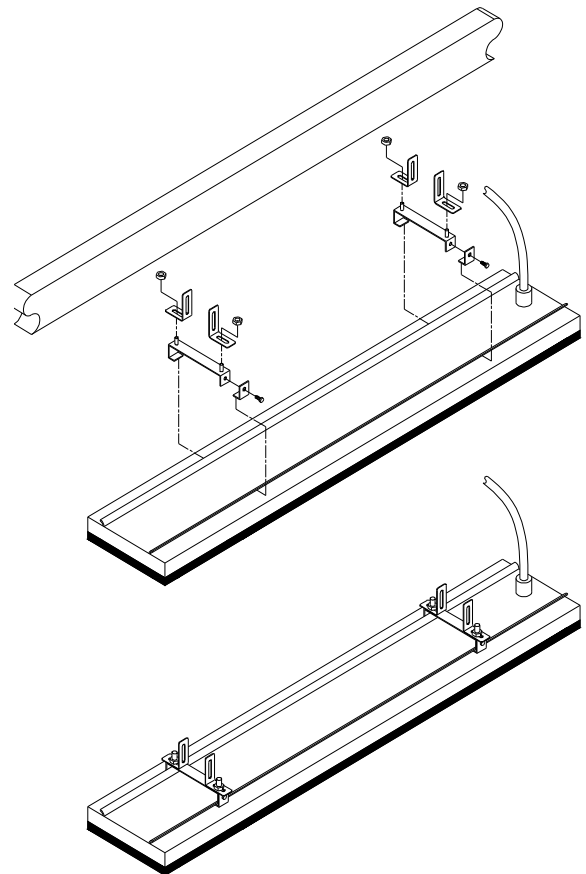
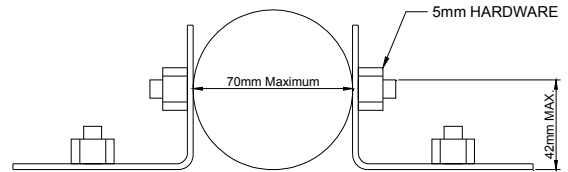
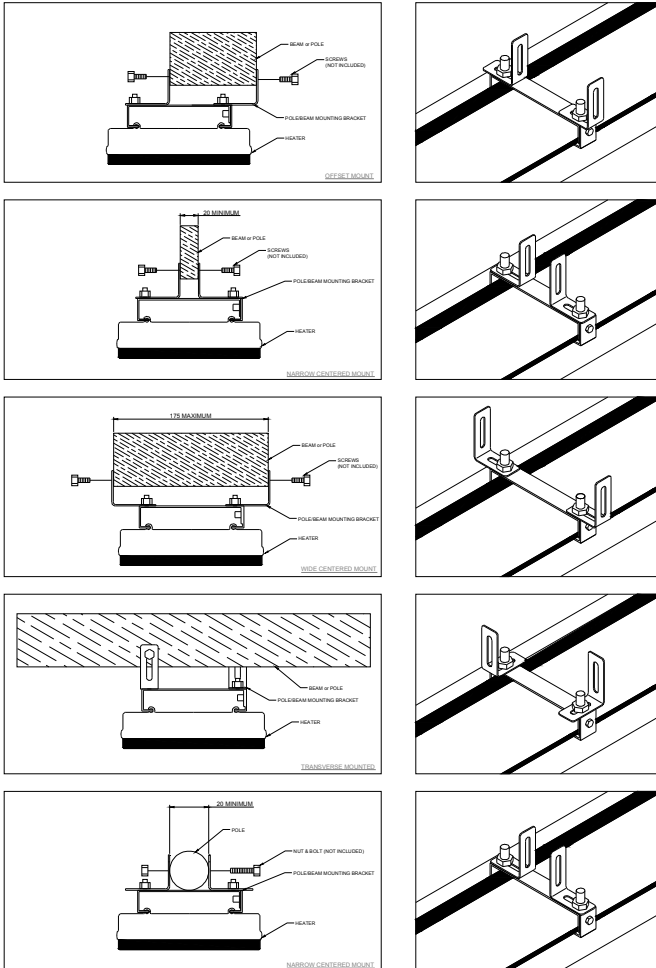

Screws for connection to the beam or pole are not included.

**Minimum pole diameter 20mm.**

**Maximum pole diameter 70mm.**

This mounting option is suitable for umbrella struts. The beam/pole can be placed directly on top of the mounting bracket. No clearance is required from the top bracket to the bottom of beam/pole.

PART No	PACKAGED DIMENSIONS (mm)	WEIGHT (kg)	MATERIALS
THHAC-001	150 x 150 x 50	0.5	316 SS



## Twin mounting bracket

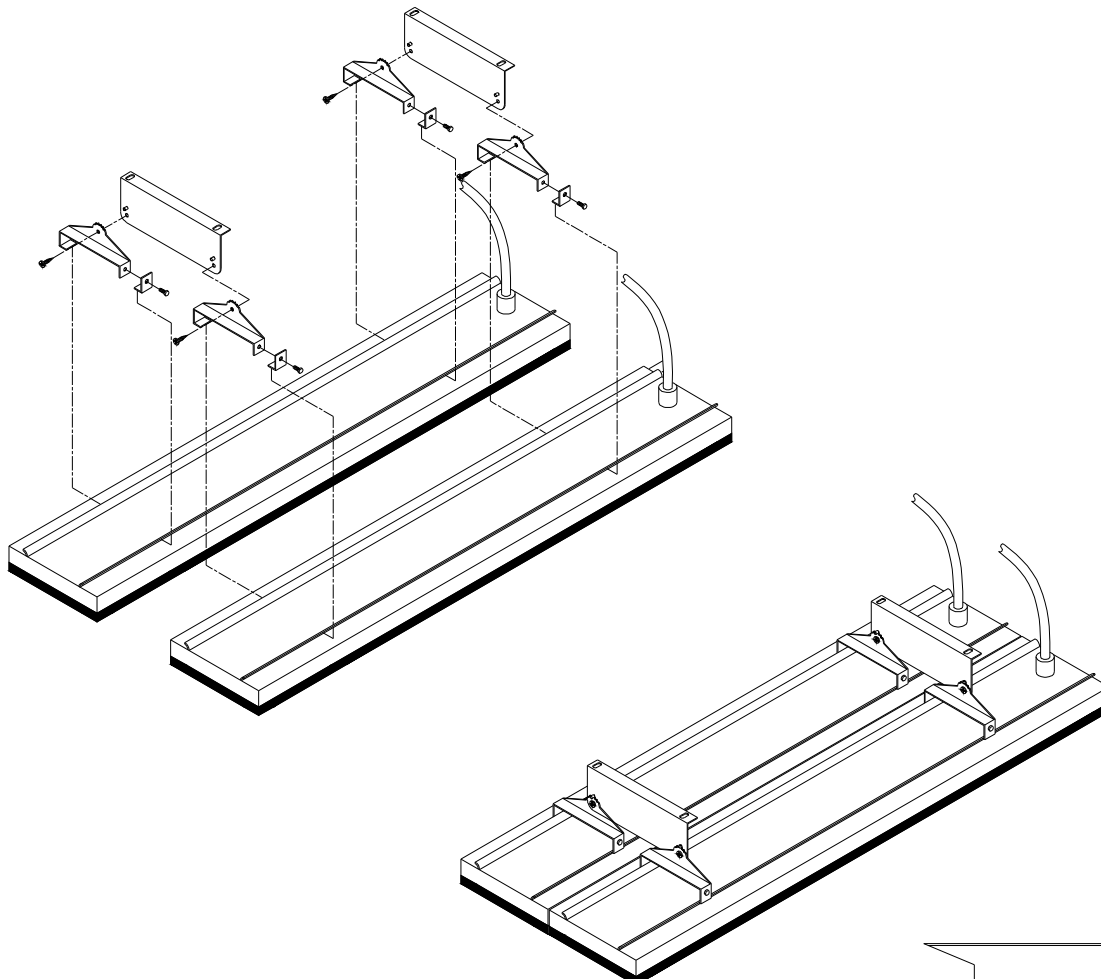

The optional Twin Mount bracket allows for two (2) units of HEATSTRIP Classic to be mounted side-by-side, either in parallel or angled as per the diagram on the right. This is ideal for applications when a wider heat coverage is required, or when there is mounting restrictions/limitations (such as running between 2 rows of tables etc.)

The Twin Mount bracket can also be used with the Extension Mount bracket and Pole Kit, to lower the units from a high ceiling.

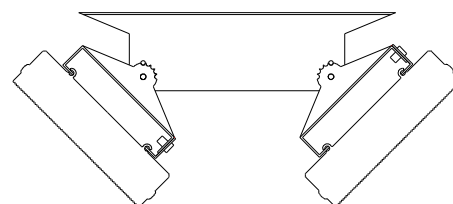
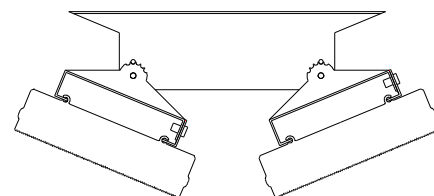
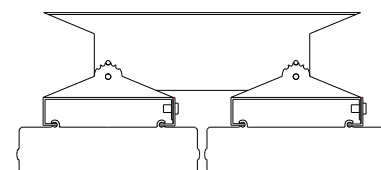

PART No	PACKAGED DIMENSIONS (mm)	WEIGHT (kg)	MATERIALS
THHAC-016	300 x 50 x 50	0.25	316 SS



## End to end mounting bracket

The end to end bracket allows multiple units to be joined in a straight line for maximum heat performance and aesthetic appeal. This is ideal for applications such as long rows of tables and assembly lines, where a constant heat coverage is required.

The bracket allows for a 50mm gap between units and an opening for the power connection. As per the diagram below, units should be mounted with the power leads together.

The end to end bracket can be used with either the standard ceiling/wall mount bracket or the extension bracket & pole kit.

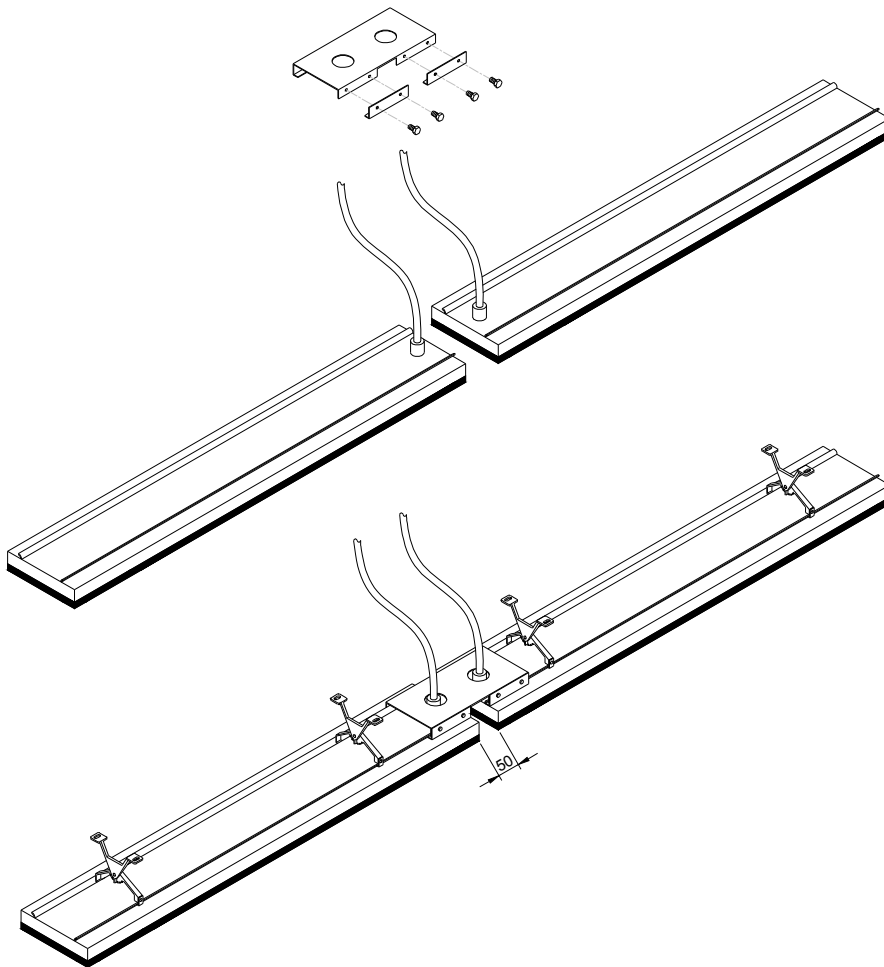

PART No	PACKAGAED DIMENSIONS (mm)	WEIGHT (kg)	MATERIALS
THHAC-017	300 x 150 x 50	0.5	316 SS



## Suspension mount bracket

The Suspension Mount bracket provides a cheap, easy and effective option for lowering the HEATSTRIP® Classic from high ceilings. If the ceiling height is more than 3.0m in an enclosed outdoor environment, or 2.7m in an exposed site, it is recommended to lower the heaters to an ideal mounting height of 2.3m—2.7m. The bracket is designed to be used with chains or wires. There can be multiple chain/wire arrangement options, as per the below diagram.

**Note: chains or cable are not supplied with the heaters**

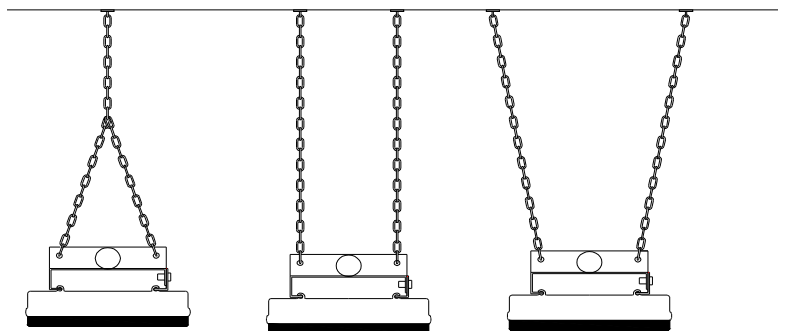
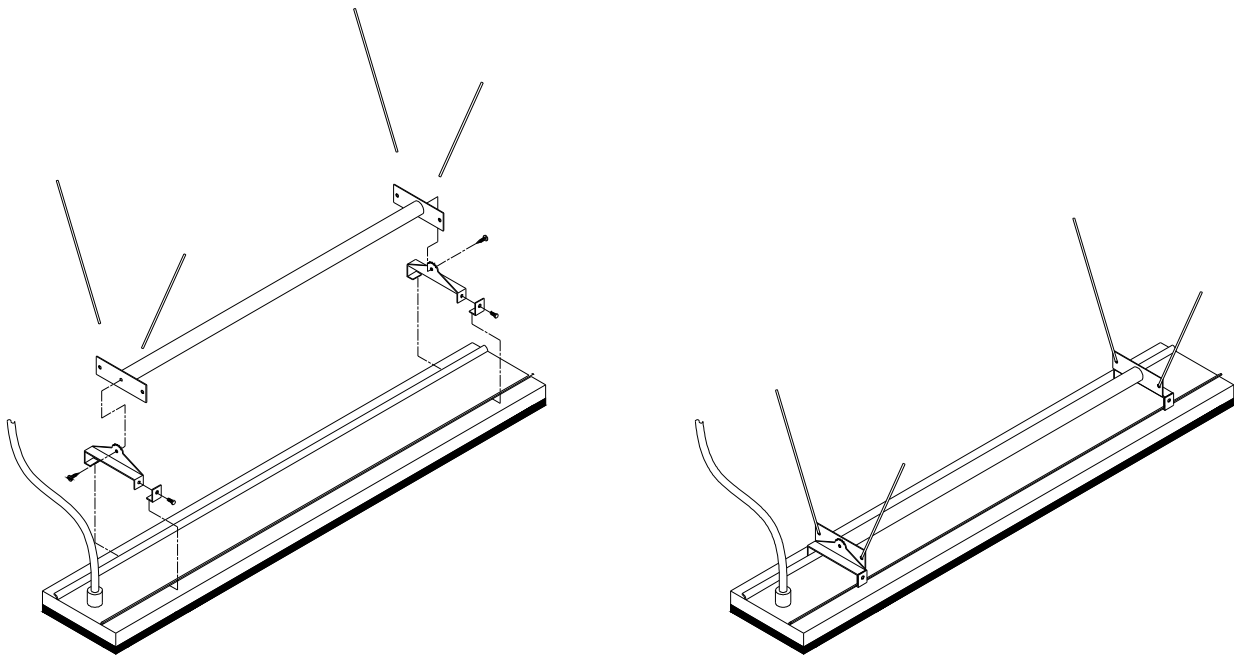

SUITABLE FOR MODELS	PART No	PACKAGED DIMENSIONS (mm)	WEIGHT (kg)	MATERIALS
THH1 500A THH 1800A	THHAC-002	300 x 150 x 50	1	316 SS
THH 2400A THH 3200A	THHAC-003	1200 x 120 x 50	2	316 SS



## Extension Mount Bracket

The Extension Mount bracket allows HEATSTRIP® Classic units to be lowered from high ceilings, using rigid connections. The brackets are for use with 25mm x 25mm x 1mm tube (SHS), and can be supplied as brackets only for customising the length of the drop on site; or supplied as a complete kit with brackets, pre-cut poles and connections. The standard length options as part of the kit are 150mm, 300mm, 600mm and 1200mm.

The kits include all brackets, poles and screws necessary for connection to the heaters, however it does not include screws for attachment to the ceiling.

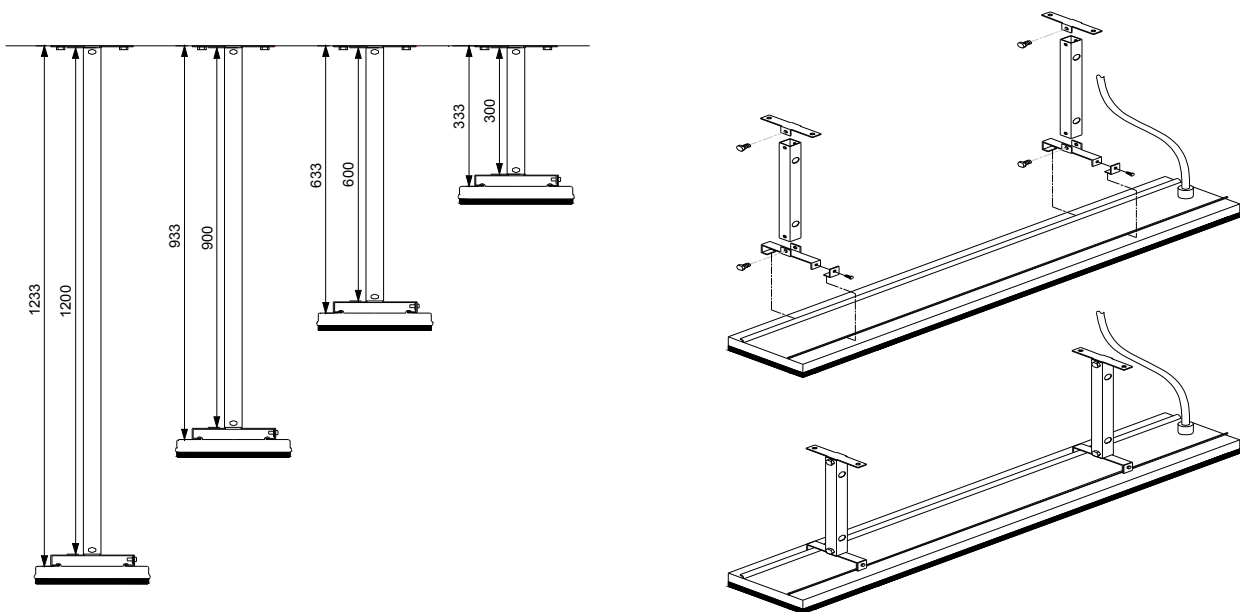

PART No	PACKAGED DIMENSIONS (mm)	WEIGHT (kg)	MATERIALS	NOTES
THHAC-004	150 x 150 x 50	1	316 SS	Brackets only (for use with 25x25x1mm tube)
THHAC-005	300 x 150 x 50	2	316 SS	Kit includes 2x300mm extension pole, screws and brackets
THHAC-006	600 x 150 x 50	2	316 SS	Kit includes 2x600mm extension pole, screws and brackets
THHAC-007	900 x 150 x 50	2.5	316 SS	Kit includes 2x900mm extension pole, screws and brackets
THHAC-008	1200 x 150 x 50	3	316 SS	Kit includes 2x1200mm extension pole, screws and brackets



## Permanent Umbrella Guide

HEATSTRIP® Classic heaters can be mounted underneath most commercial grade, permanent umbrella's or shade structures. The material must protect the heater from direct rainfall. All models can be connected to the horizontal umbrella's struts, using the Pole/Beam mounting kit (THHAC-001).

### Quick reference guide for spot heating common permanent umbrella structure:

9m2 umbrella area	4 x THH 1500A
12 m2 umbrella area	6 x THH 1500A or 4 x THH 1800A
16 m2 umbrella area	8 x THH 1500A or 6 x THH 1800A

This is a guide only. For more detailed information, please contact the umbrella manufacturer, your nearest HEATSTRIP retailer or Thermofilm.

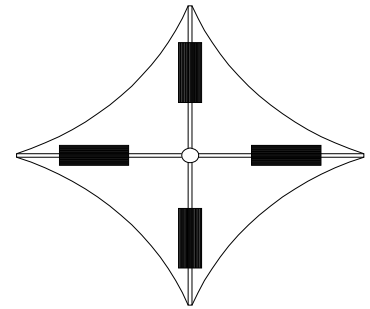
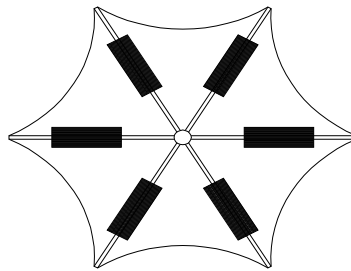
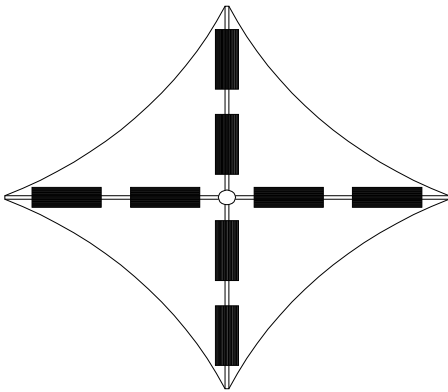



## HEATSTRIP® Controller

The HEATSTRIP® Classic can be controlled via a simple on/off wall mounted switch, however it is recommended to use a controller with a variable heat modulator and a timer, to give the best performance and lowest running cost.

### TT-MTM wall controller

This controller is a custom designed and manufactured controller for Heatstrip. It has been designed for ease of use and low running costs of your heater. It provides both temperature control (allowing the user to turn the heat output up or down depending on the ambient temperature and conditions) and a timer for automatic heater operation.

The count down timer function has four settings. It can be 1 hour, 2 hours or 4 hours or constantly on. This is ideal when continuous heat is not required. For example a BBQ, alfresco areas, restaurant dining, assembly line production etc. It is simple to use, just press the time button and it will switch on, press again and it will be 1 hour. After one hour the heater will switch off.

Depending on the ambient temperature, there may be a requirement to control the operation of the heater (standard ON position is at full power and temperature). The controller has 3 settings - High, Medium and Low.

The controller allows a combination of the multiple timer (1/2/4 hour) and heat outputs (High/Medium/Low). The default operation is continuous operation at full temperature.

### Controlling multiple units

It is possible to use one wall controller to control multiple heaters. The wall controller is rated at 15 Amps and 240 volts. For larger current draw, it is recommended that you talk to your electrician who can use a time delay relay to connect more units.

The controller needs a minimum of 250W on the load before it starts working. If connecting multiple units ensure one unit is connected directly to the controller and the others are connected using a contactor.

### Thermostat controllers

Thermostat controllers are NOT recommended. The temperature sensor for this type of controller is usually measured by the air temperature. The Heatstrip is a radiant heater where objects are heated, not the air. In open indoor or outdoor areas, it is very difficult to contain warm air within the space and therefore accurately measure air temperature. This may result in unnecessary, continuous operation of the unit.

### Dimmers

The use of dimmers with the HEATSTRIP is NOT recommended.

Please refer to the Product Installation Manual for more detailed product data.



MODEL	MAXIMUM VOLTAGE (Volts)	MAXIMUM CURRENT (Amps)	PACKAGED DIMENSIONS (mm)	WEIGHT (kg)
TT-MTM	240	15	140 x 90 x 60 Actual Product Dimensions: 75mm x 120mm	0.5



## Safety

HEATSTRIP® Classic has an IP rating of 55. This means it is safe for water ingress from all directions. The HEATSTRIP® can be safely hosed down.

HEATSTRIP® has undergone extensive testing both in laboratory conditions; in Thermofilm's manufacturing facility in Melbourne and field trials in Australia and overseas. It is this testing that gives the purchaser the confidence of a high quality product.

Independent laboratory testing has confirmed Thermofilm's full compliance with Australian and other International Standards. This includes CE, AS/ANZ, UL/CSE

The heater comes in both plug (1500W, 1800W, 2400W) and hardwired (3200W) versions. In both cases the fixed wiring must be installed by a licensed electrician in accordance with the relevant wiring regulations.

HEATSTRIP® is Class 1 equipment and must be earthed.

In operation, this heater is VERY HOT— do not touch any part of the heater while it is turned on. Do not touch any part until 30 minutes after it is turned off.

This appliance is not intended for use by persons (including children) with reduced physical, sensory or intellectual capabilities, or lack of experience and knowledge, unless they have been given supervision or instruction concerning use of the appliance by a person responsible for their safety. Children should be supervised to ensure they do not play with the appliance.

Do not allow any cables, furnishings, flammable materials or other items come in contact with any surface of the heater.

If installed in wet areas, the heater switches or controls must be located so that they cannot be touched by persons in the bath or shower.

The heater needs to be installed as per the installation instructions paying special attention to the minimum clearances. The heater needs to be mounted on a rigid bracket or fixing.

The heater must not be mounted immediately below or in front of a socket outlet.

In case of a heater fault or damaged supply lead, the appliance should be returned to the point of purchase for return to Thermofilm for repair.

## Maintenance

The HEATSTRIP® Classic is made from durable materials, however regular care and maintenance of your heater will help prolong the life of the heater.

It is recommended that you hose down the heater and with a soft cloth gently wipe the surfaces of the heater with a mild detergent to remove the built up contaminants from the environment. Then rinse all detergent off the heater. All chemicals in the atmosphere including cigarette smoke, pollution etc. will tarnish the surface of the heater. In this case, additional cleaning and maintenance may be required. Carrying out the cleaning process at least every three months will reduce the amount of build up and keep the Heatstrip in good condition. If the heater is in a corrosive environment eg. salt spray, we recommend that you clean your heater with a light spray of fresh water every week. After cleaning, turn the heater on for 20 minutes to dry any water residue and prevent water staining.

Before cleaning or inspection activity, the heater must be switched off and cooled down completely.

Do not use any abrasive materials or products to clean the heater, this includes solvents, citrus based cleaners or other harsh cleaning products.

When handling the heater, ensure that your hands are clean or that you use clean gloves as grease or dirt can mark the surface of the heater.

Do not use high pressure water to clean heaters, light water spray only.



## Heater wiring schematic diagrams

The HEATSTRIP<sup>®</sup> heater is required to be fitted with an "ON/OFF" isolation switch and can also be controlled with the use of a timer type control. It is recommended to use the TT-MTM Wall Controller for maximum performance and control options. Ensure the unit is turned OFF after use.

For direct wiring to the controller, the maximum is one heater unit unless it is two THH1500A.

For multiple units from one wall controller it is recommended to talk your electrician who will use a relay or contactor.

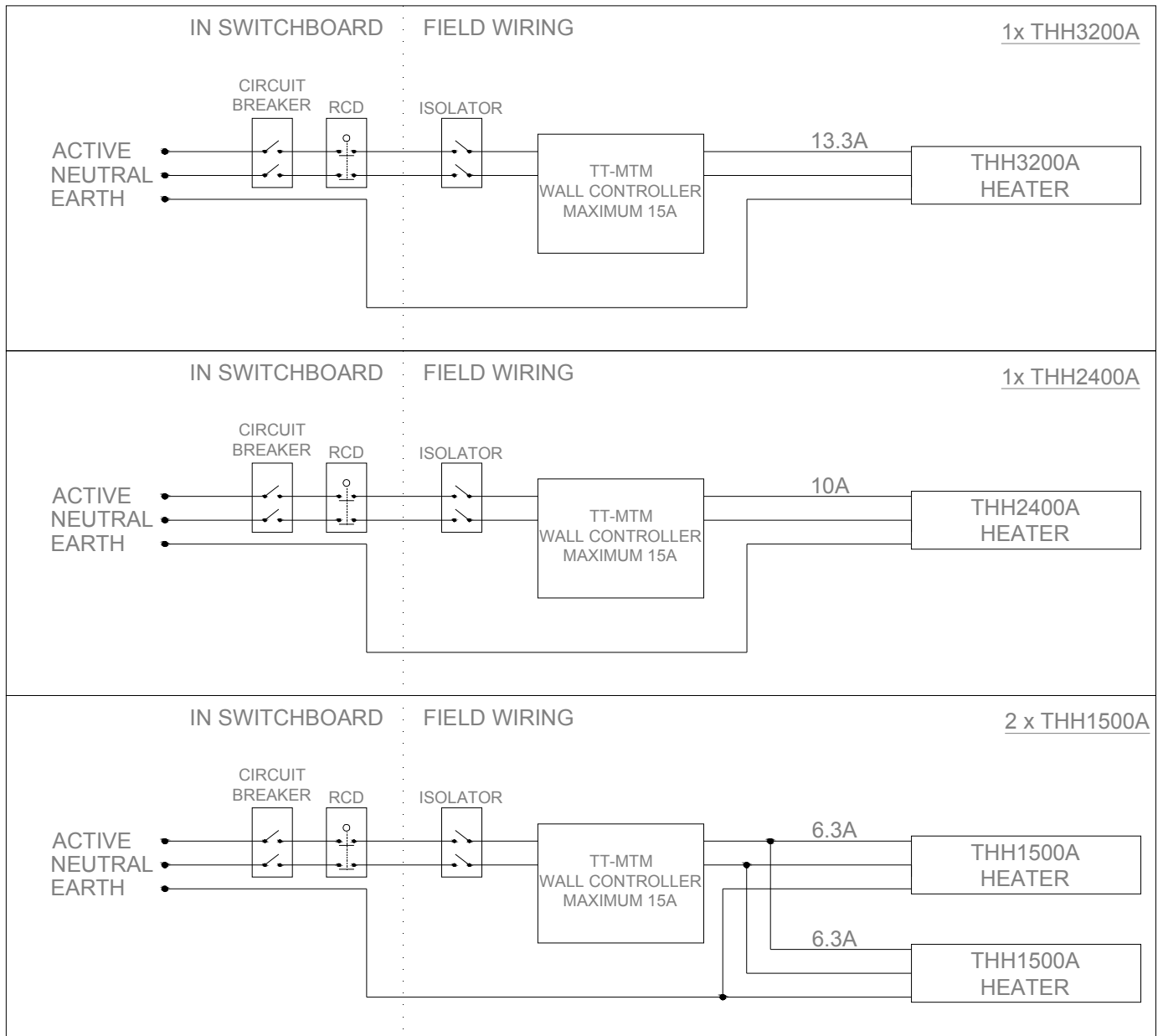



## Heater wiring schematic diagrams with relays

When more heating units need to be connected from the same switch, a relay is needed. It is recommended that you talk to your electrician for more detail.

When using contactors or relays ensure there is a minimum load of 250W on the controller.

Below are some circuits that will help with this situation.

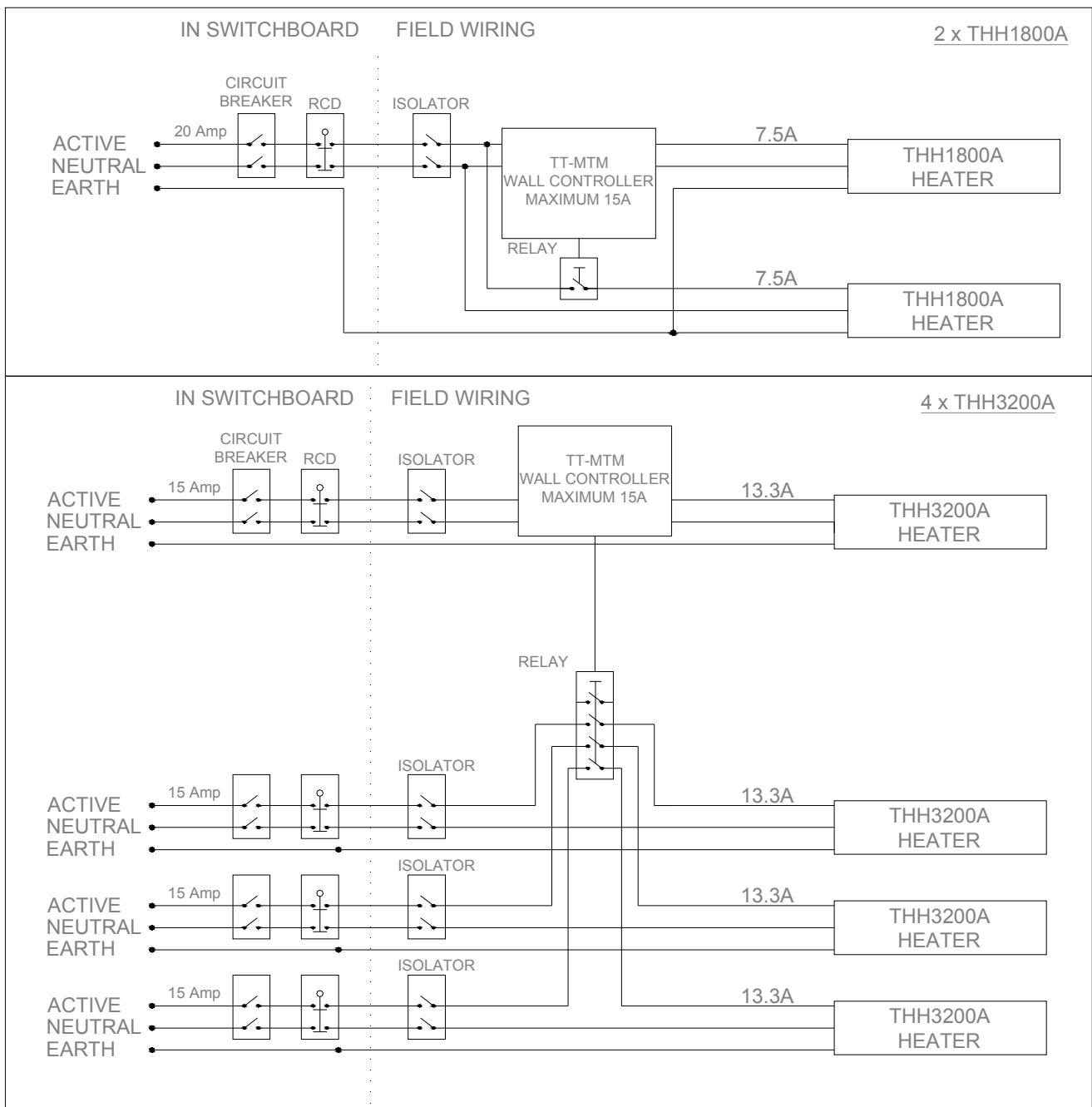



## Warranty Terms & Conditions

The below Warranty Terms and Conditions apply for **New Zealand and Australia only**. For international warranty please refer to international warranty terms and conditions.

Thermofilm warrants to the original owner that HEATSTRIP® Classic products will be free from defects in materials and workmanship for a period of 24 months for residential use from the date of purchase in accordance with the following warranty terms and conditions. For commercial use warranty is 12 months.

Provision of this warranty is subject to:

- The HEATSTRIP® product must be installed in accordance with the Installation Instructions and relevant electrical standards and codes.
- The HEATSTRIP® product must be maintained and cleaned according to instructions detailed in the Installation Manual.
- There is no warranty expressed or implied with regard to capacity requirements. The selection of the unit or units depends entirely upon the system design and capacities as determined by the purchaser.
- The customer has not repaired, opened or altered the product in any unauthorised manner.
- This warranty excludes damage to the product or components arising from circumstances outside the control of Thermofilm, including, but not limited to, where the product is not used for intended purpose; where the product has been rectified in any way; incorrect installation; incorrect power supply; damaged caused during delivery; misapplication, misuse, abuse, vandalism, lack of maintenance or accident.
- Thermofilm's obligations under this warranty are limited to repair or replacement at Thermofilm's factory of any components of the product which Thermofilm identifies to its satisfaction to be defective.
- Transportation charges involved in return of the product to the Thermofilm factory (or any other location authorised in writing by Thermofilm) is the sole responsibility of the customer.
- All products are inspected and tested before despatch and are at the risk of the purchaser after the shipment from the Thermofilm factory, if not delivered by Thermofilm to destination.
- Discolouration of the surface may occur after a period of time, this does not constitute a warrantable event.
- Twisting and bending of the heaters may occur, this does not constitute a warrantable event.
- No products or components will be supplied in advance of an examination of the faulty product or components by Thermofilm or an authorized representative of Thermofilm.
- Thermofilm does not participate in any site related costs or labour expenses incidental to replacement of parts, repairing, removing, installing, servicing, transportation or handling of parts to complete products, and assumes no liability on parts repaired or replaced without written authorisation. Thermofilm shall not be liable for any default or delay in performance of its warranty obligations caused by any circumstances beyond its control, including, but not limited to, judicial or government restrictions, strikes, fires, floods, abnormal weather conditions, delayed supply of components.

Should products be determined as damaged on arrival, immediately notify the transport company of the condition and have them noted on the freight documents. If damage is discovered after unpacking, demand immediate inspection by the transportation company and insist that a record of the damage is made on the freight documentation.

The customer warrants using the product in accordance with:

- Any instructions provided to it by Thermofilm from time to time.
- All government and local regulations, including but not limited to all relevant electrical, environmental laws and regulations governing the installation, storage, use, handling and maintenance of the goods.
- All necessary and appropriate precautions and safety measures relating to the installation, storage, use, handling and maintenance of goods.

*Our goods come with guarantees that cannot be excluded under the Australian Consumer Law. You are entitled to a replacement or refund for a major failure and for compensation for any other reasonably foreseeable loss or damage. You are also entitled to have the goods repaired or replaced if the goods fail to be of acceptable quality and the failure does not amount to a major failure.*

All warranty requests for repairs or replacements must be accompanied by a complete "Warranty Claim Form" available from Thermofilm, together with proof of purchase (and where possible, photos of the installation) and the heater returned to the place of purchase.

In the event of a warranty claim, the goods need to be returned to the distributor/retailer for repair/replacement. Contact

Thermofilm Australia Pty Ltd  
 27 Rosalie Street, Springvale, Victoria 3171, Australia  
 Telephone: (03) 9562 3455,  
 Email: [info@thermofilm.com.au](mailto:info@thermofilm.com.au)